

INSTALLATION MANUAL

THE LAB LEGEND SHIFTER

<i>Paddles assembly:</i>	2
<i>Actuator assembly:</i>	3
<i>Electric wiring assembly:</i>	4
<i>Cut-Off connection:</i>	4
<i>Blipper connection:</i>	5
<i>Electronic accelerator:</i>	6
<i>Gear counter connection:</i>	7
<i>Power connection:</i>	8
<i>Note:</i>	8
<i>Wiring diagram:</i>	9

Paddles assembly:

The paddles kit is supplied already assembled, it will be enough to install it between the steering wheel and the hub using the existing holes or, if necessary, drilling the carbon plate as you need.

It is possible to distance the paddles from the steering wheel by inserting between the paddles and the hinges the spacers and using longer screws (standard TBEI M4x14).

It is extremely important to attach the harness to the steering wheel with two cable ties or with tape to allow the relaxation of the spiral only.



Actuator assembly:

1) Secure the actuator with an appropriate bracket to the engine block or as close as possible to the gearbox arm of the engine;

1) 2) Align the actuator to keep the engine gearbox arm at the same angle as the actuator arm. Here are illustrative images:

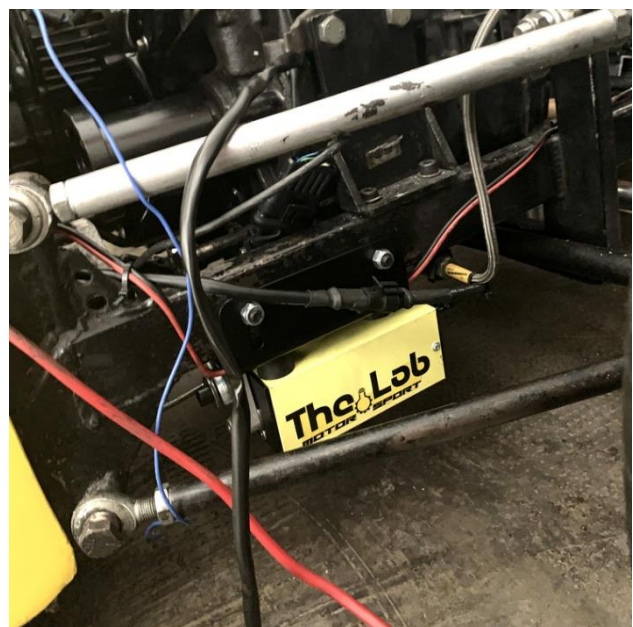
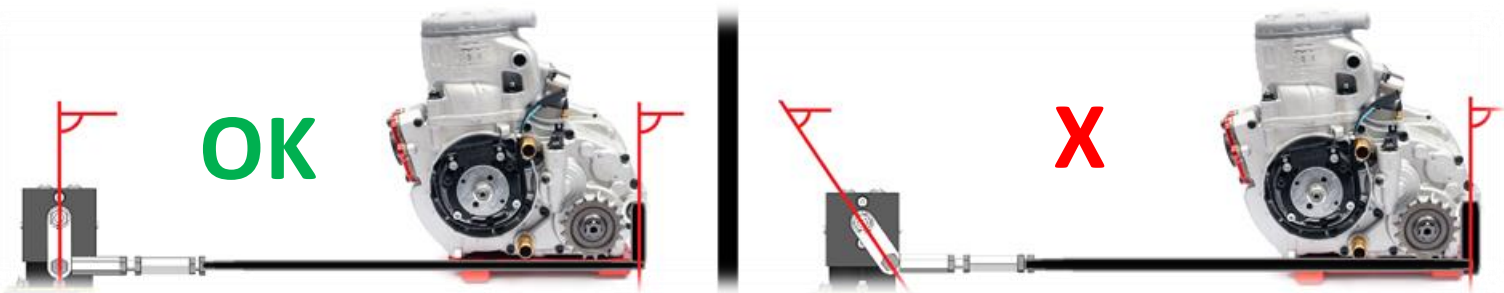

Electric wiring assembly:

The electrical system is plug&play, all connectors are designed in such a way that they can not be reversed. On the terminal part of the free cables there is a label indicating the function. Connect the cable "GND car" (black) to ground on the vehicle as a first pass.

C: Common

NO: Normally open

NC: Normally closed

Comp+: Positive compressor (+12-18V)

Gear 1/2/3/3/4/5/6: Gears 1/2/3/4/5/6

Cut-Off connection:

To connect the Cut-Off, connect the "Cut-off C" cable (white) and the "Cut-off NO" cable (green) in parallel to the engine shutdown button, or (in the event that the shutdown cuts off power to the motor control unit) interrupt the ground cable of the coils with the specific wiring.

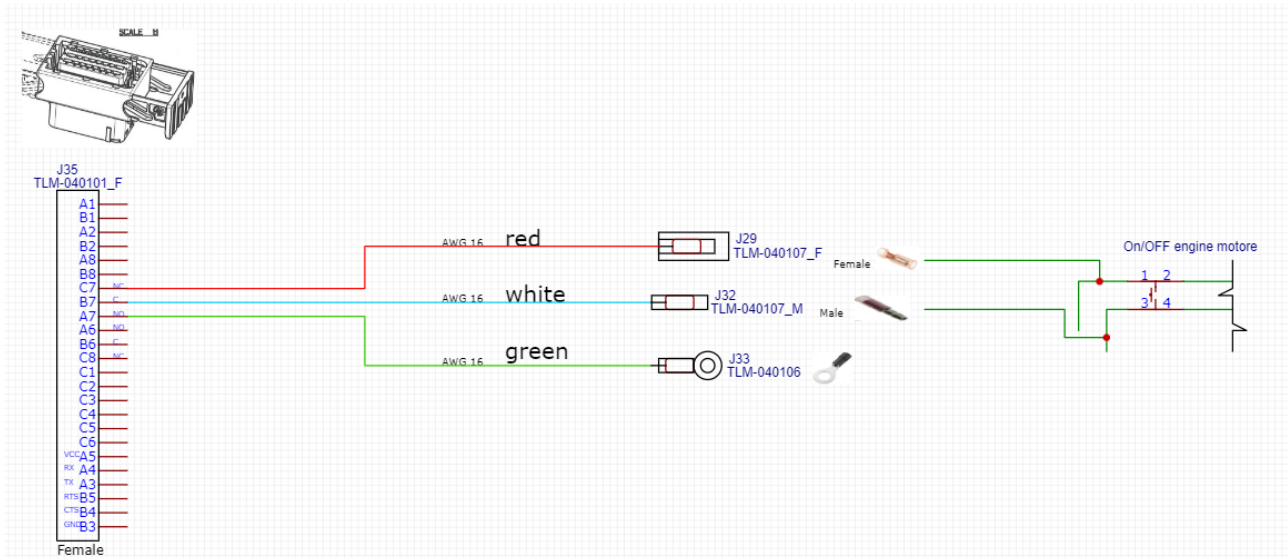

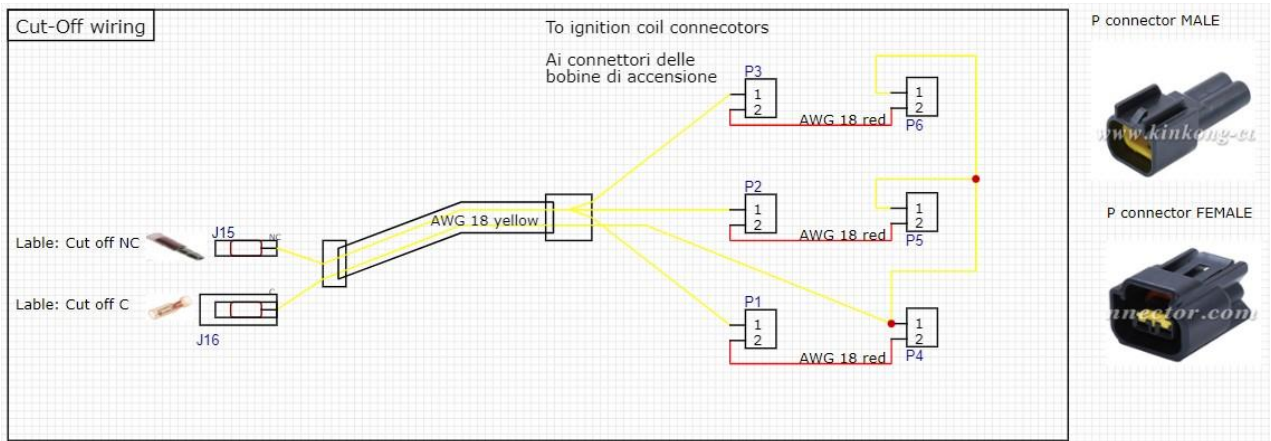

Blipper connection:

There are two solutions for mounting the blipper depending on the presence of the electronic accelerator or the wire accelerator:

Wire throttle:

If you purchased the kit with blipper actuator then you will need to connect the black cable of actuator to the ground and the red cable to the "Blipper C" (brown) cable.

Next you will need to connect the positive of the vehicle (+12-18V) to the cable "Blipper NO" (black).

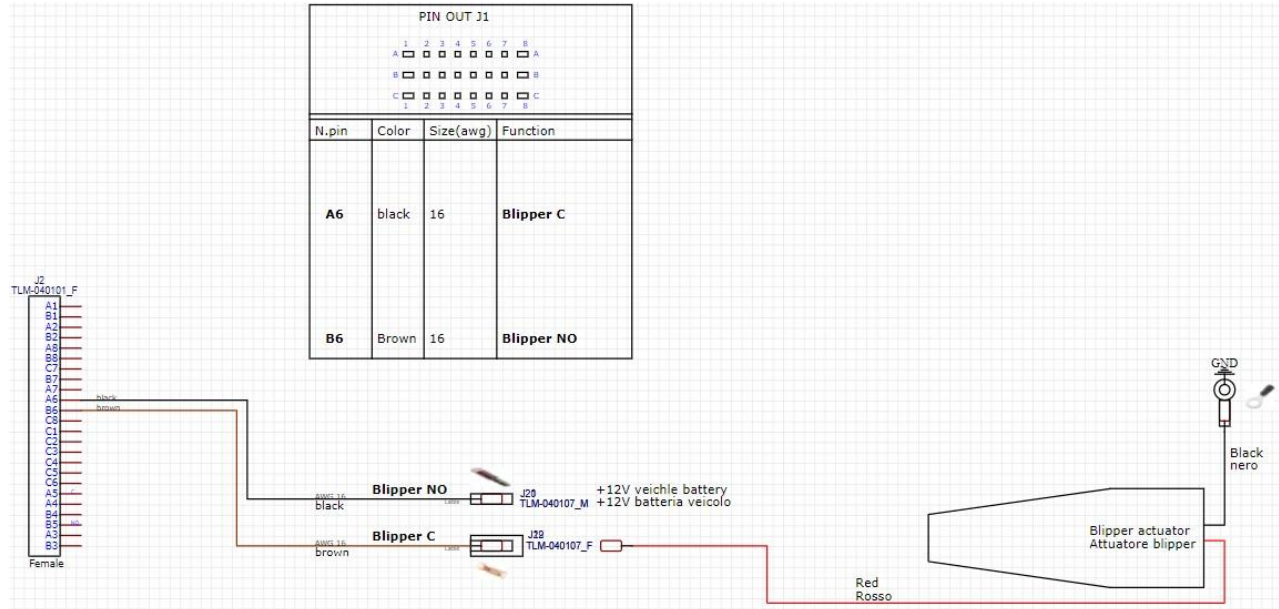

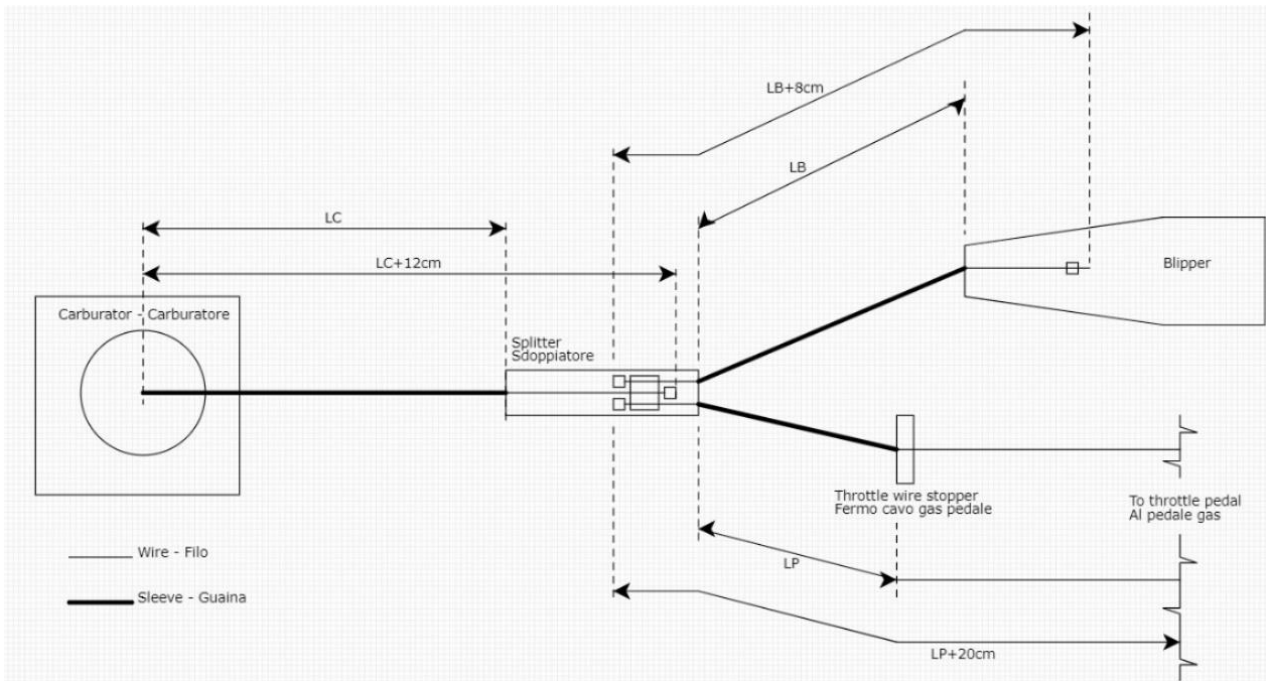

Electronic accelerator:

If the vehicle is equipped with an electronic accelerator, you must intercept the accelerator potentiometer cables:

Connect the specific wiring by following the following connection diagram:

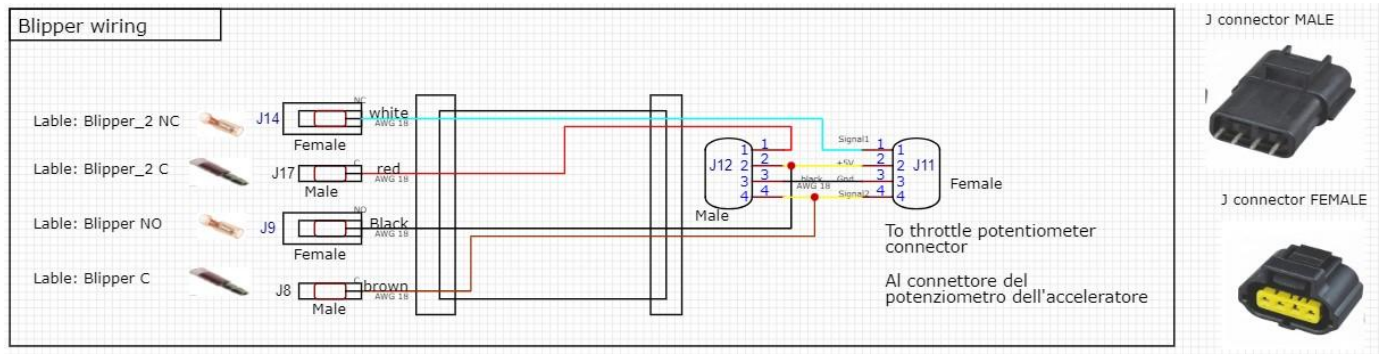

Attention:

1. The blipper actuator can be operated with both the electronic and the wire accelerator using the gas cable;
2. If you only want to get GND signals to be used in the engine unit that will then handle the cut-off and the blipper, you can always connect to ground (GND) the cables "Blipper C" (brown) and "Cut-off C" (white) to ground (GND) and you will have an output on the respective NO and NC GND input to be sent to the control unit;
3. If the wiring is not long enough, it is advisable to cut and lengthen the part of the wiring that connects to the paddle (3 pins female connector), or to request the extension kit for the paddles.

Gear counter connection:

The system can read the gear in order to adjust the parameters. It is necessary to join the 6 "gear 1-6" cables to the respective cable on the gear sensor. It is also possible to use the specific connector on the wiring to be connected between the original connectors of the gearbox sensor.

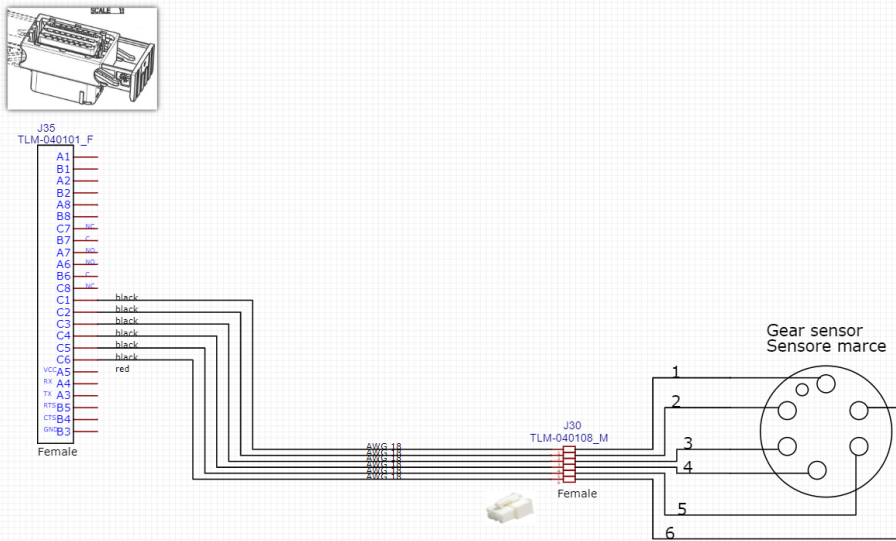

Power connection:

- 1) Connect the "GND car" cable to the vehicle mass (GND vehicle battery);
- 2) If you use the dedicated lipo battery connect the power connector with the lipo battery, otherwise connect the power connector to the power balance and connect the red cable to the positive of the vehicle (+12/18V) and the black ground cable (vehicle GND) with suitable connectors;

Note:

Wiring diagram:

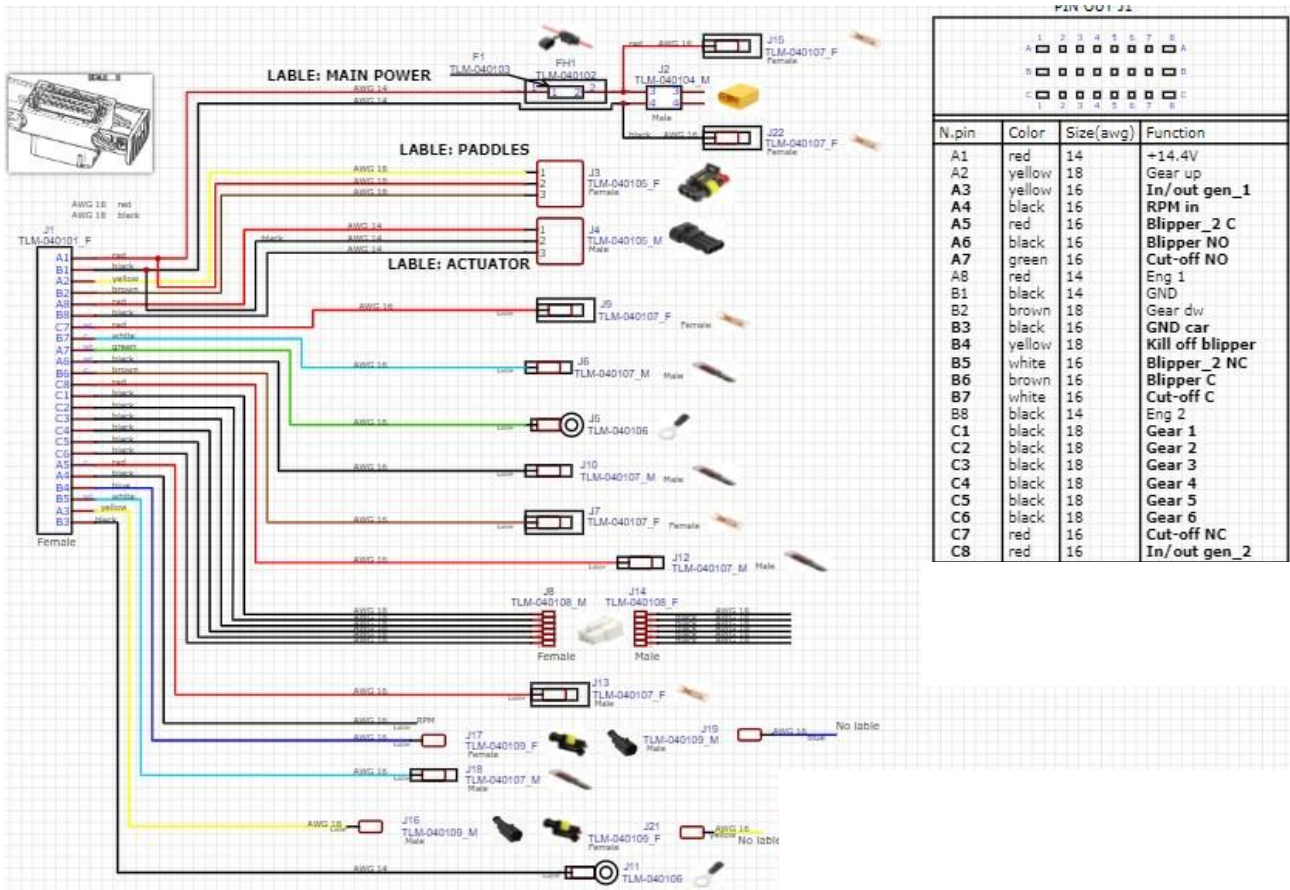

The Lab Motorsport
 Via Donatello 12/A
 MONZA (MB)
 ITALY
 +39 3484682833
 info@thelab-europe.com